



# MODULINE

*foodfinish & foodserve technologies*



HOLDING SYSTEMS

## HHT081E

Static holding trolley



### CONSTRUCTION FEATURES

- Tightness chamber with radius corners
- Rubber bumpers
- Total thermic insulation with rock or glass wool
- Long lasting front and door seals made up of food grade of high heat resistance
- Removable side racks to facilitate cleaning
- Static heating provided by low consumption wise heating element that covers up all the chamber
- Snap-shut door
- Mounted on four 125 mm diameter castors, two of which with brake
- Ergonomic handle for pushing and guiding
- Easy access to facilitate maintenance and repair

### FUNCTIONAL FEATURES

- Electronic control of the temperature
- Operating temperature 30°-120°C
- Two adjustable humidity vents on the door
- Chamber with safety thermostat

### STANDARD SUPPLY

- Removable GN 1/1 tray racks

### OPTIONS & ACCESSORIES

- No



FOOD SERVICE EQUIPMENT

02 4228 9733 [sales@wgafoodequip.com.au](mailto:sales@wgafoodequip.com.au)



# MODULINE

*foodfinish & foodserve technologies*

HOLDING SYSTEMS

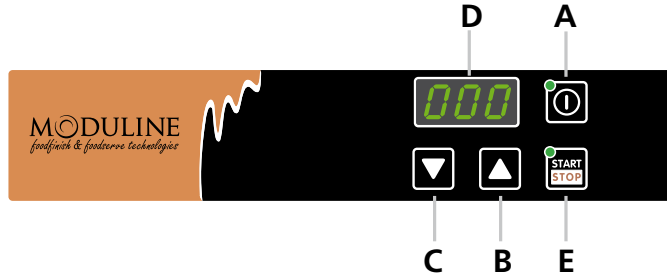

- A ON/OFF switch
- B Temperature increase key
- C Temperature decrease key
- D Display
- E START/STOP key

TECHNICAL INSTALLATION DIAGRAM

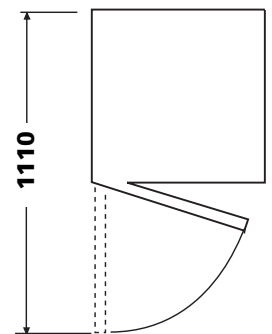
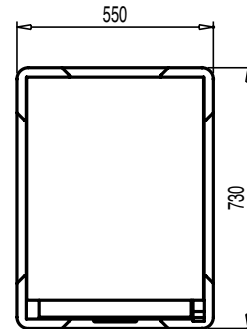
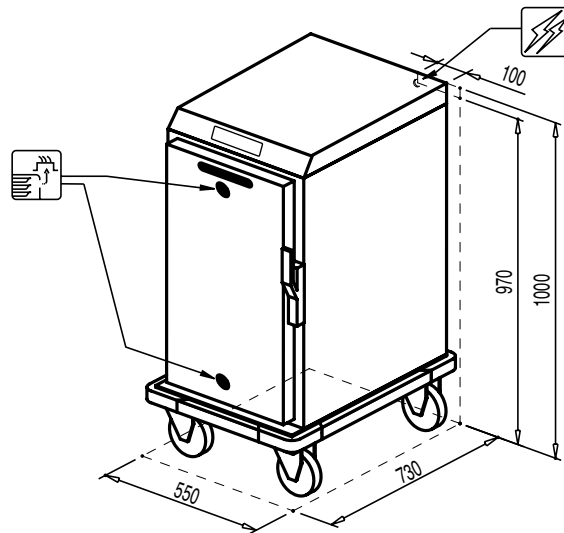

Electricity supply cable inlet 

Adjustable vent for release of excess humidity 

Model	Overall dimensions (W x D x H) - mm	Trays capacity	Power kW	Power supply
<b>HHT081E</b>	550 x 730 x 1000 h	8 x GN 1/1	1	AC 230 V / 50 Hz